

# SUNDANCE Skiff Series

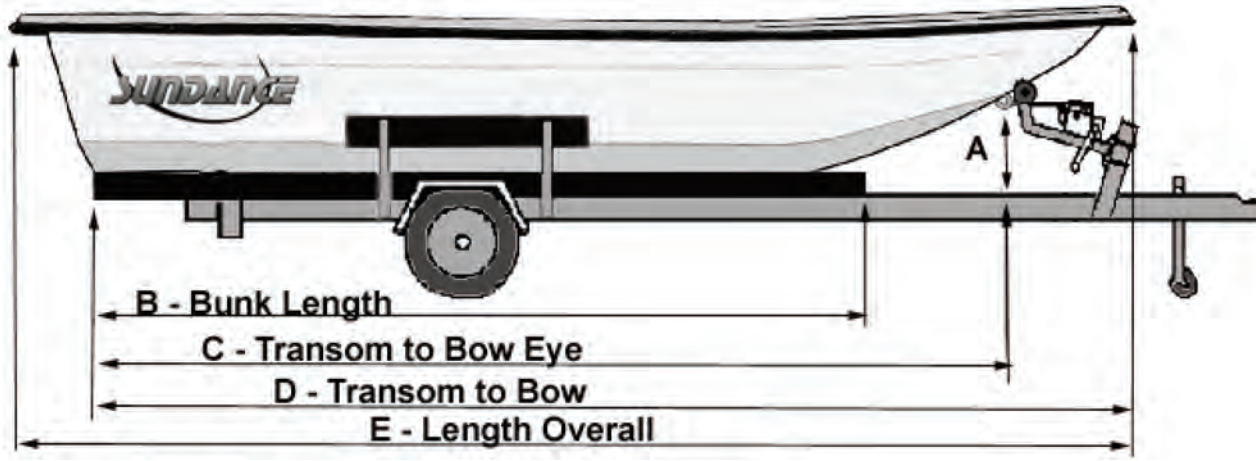

COMPOSITE RESEARCH, INC

Recommended Bow Stop and Side Rollers - DO NOT USE Carolina Skiff style boards



Winch Post Height		
Series	Min.	Max.
K	14"	20"
F	18"	22"
B & DX	22"	26"

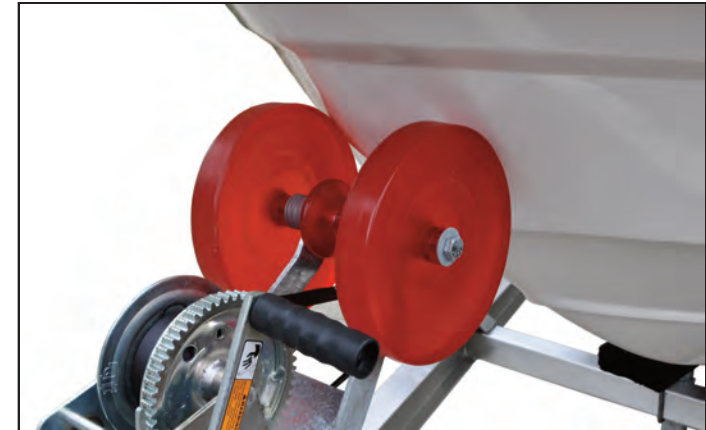

1. CRI does not recommend roller style trailers. Roller trailers will void your hull warranty.
2. All Skiff Series boats have a cored hulls. Do not use keel rollers.
3. 4 Bunks required on B and DX Boats and any boat used in commercial applications.
4. The trailer bunks MUST fit the flat part of the hull bottom. Chines, center keels and strakes MUST fit between the bunks. Boats transported with keels, chines or strakes on top of bunks could result in hull damage.
5. The forward end of the bunks must extend beyond the flat portion of the boat.
6. All bunks must be constructed of 2" x 6" treated wood covered with carpet.

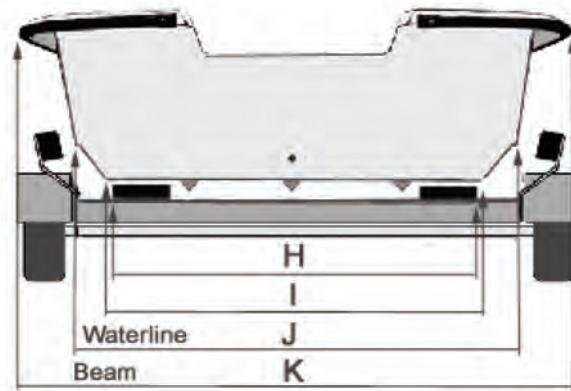
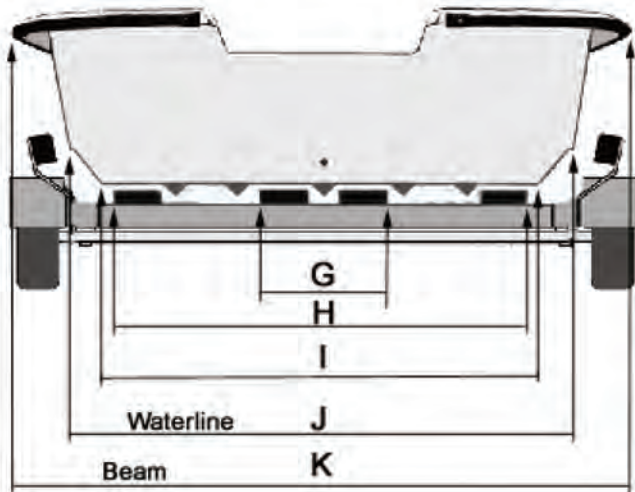

Locating 4 foot long carpeted side guides over the wheel fenders is recommended for easy loading.

Model	A	B	C	D	E	F	G	H	I	J	K	W1	W2
K14	10"	8'-0"	11'-8"	13'-0"	13'-10"	0	N/A	35-1/2"	44"	55"	64"	580	950
K16	10"	10'-0"	13'-8"	15'-0"	15'-10"	0	N/A	35-1/2"	44"	55"	64"	680	1080
F17	16"	10'-0"	14'-2"	15'-9"	16'-10"	0	N/A	42"	54-1/2"	65"	76"	1070	1575
F19	16"	12'-0"	16'-2"	17'-9"	18'-10"	0	N/A	42"	54-1/2"	65"	76"	1190	1800
B & DX18	23"	12'-0"	16'-6"	16'-9"	17'-11"	0	17-1/4"	68-1/4"	69-1/2"	80"	94"	1395	1960
B & DX20	23"	14'-0"	18'-6"	18'-6"	19'-11"	0	17-1/4"	68-1/4"	69-1/2"	80"	94"	1575	2230
B & DX22	23"	16'-0"	20'-6"	20'-6"	21'-11"	0	17-1/4"	68-1/4"	69-1/2"	80"	94"	1745	2490

A = Frame to Bow Eye  
 B = Carpeted Bunk Length  
 C = Transom Bottom to Bow Eye  
 D = Transom Bottom to Bow  
 E = Length Overall  
 F = Deadrise in degrees  
 G = Outside deminsion of inner 2x6 Bunks  
 H = Outside deminsion of outer 2x6 Bunks  
 I = Beam at bottom of boat  
 J = Beam at Waterline spray chine  
 K = Beam Overall  
 W1 = Weight of Hull Only - Heaviest Model in Series  
 W2 = W1 plus, Max Engine, Fuel, Batteries, Gear